

Mark 627 Series

High Pressure Regulators

The Jordan Mark 627 self-contained pressure-reducing regulator is designed to provide tight shut-off and accurate regulation on low or high pressure systems. It can be used on air, natural gas or a variety of other gases.

FEATURES

- Inlet pressures to 2000 psi (137,9 bar)
- Tight shutoff
- Top entry design allows easy in-line maintenance
- Tamper resistant protective cap
- 316 Stainless Steel orifice standard, multiple sizes

SPECIFICATIONS

Sizes: 3/4" (DN20)*, 1" (DN25), 2" (DN50)

End Connection: FNPT (Contact factory for other options)

Materials:

- Body: Carbon Steel (WCB A216)
- Seat: 316 Stainless Steel (CF8M)
- Disc Assembly: 316SS / Neoprene and 316SS/ Nylon
- Diaphragm: Nitrile
- Diaphragm Case: Aluminum

Service: Air and Gas

Temperature Range: -20°F to 180°F (-28,9°C to 82,2°C)

Maximum Inlet Pressure: 2000 psi (137,9 bar)

- Reduced Pressure Control Range:
- 5 – 20 psig (0,34 – 1,38 bar)
- 15 – 40 psig (1,03 – 2,76 bar)
- 35 – 80 psig (2,41 – 5,52 bar)
- 70 – 150 psig (4,84 – 10,34 bar)
- 10 – 95 psig (0,69 to 6,55 bar)

Orifice Sizes (Interchangeable): 3/32" (2mm), 1/8" (3mm), 3/16" (5mm), 1/4" (6mm), 3/8" (10mm), 1/2" (13mm)

* 3/4" ACHIEVED THROUGH THE USE OF A WCB BUSHING.

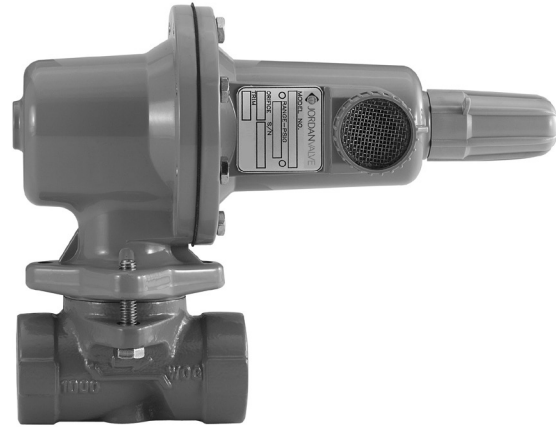

TABLE 1: MAXIMUM INLET PRESSURE, DIFFERENTIAL PRESSURE AND OUTLET PRESSURE RANGES

Outlet Pressure Range	Orifice Diameter (inches)	Maximum Inlet Pressure (psig)	Maximum Differential Pressure (psig)
5 ⁽¹⁾ to 20 psig	3/32	2000	2000
	1/8	1000	1000
	3/16	750	750
	1/4	500	500
	3/8	300	300
	1/2	250	250
15 to 40 psig	3/32	2000	2000
	1/8	1500	1500
	3/16	1000	1000
	1/4	750	750
	3/8	500	500
35 to 80 psig	3/32	2000	2000
	1/8	2000	2000
	3/16	1750	1750
	1/4	1500	1500
	3/8	1000	1000
70 to 150 psig	1/2	750	750
	3/32	2000	2000
	1/8	2000	2000
	3/16	2000	2000
	1/4	1750	1750
	3/8	1250	1250
	1/2	750	750

1. For pressure settings under 10 psig, inlet pressure should be limited to approximately 100 psig so the set point adjustment can be reached.

DIMENSIONAL DATA

TABLE 2: FLOW CAPACITIES IN SCFH OF 0.6 SPECIFIC GRAVITY NATURAL GAS ⁽¹⁾

Outlet Pressure Range	Outlet Pressure Setting (psig)	Inlet Pressure (psig)	Orifice Diameter (inches)					
			3/32	1/8	3/16	1/4	3/8	1/2
5 to 20 psig ⁽²⁾	5 ⁽³⁾	10	170	330	710	1100	1900	2500
		15	240	390	890	1600	250	3350
		20	290	500	1160	2060	3400	4450
		30	380	670	1560	2800	4750	6900
		60	640	1170	2600	4710	8140	13700
		75	770	1410	3150	5710	9790	14500
		100	990	1800	4070	7310	12500	16000
	10	15	210	375	880	1590	2480	3300
		20	280	490	1150	2050	3380	4410
		30	380	670	1560	2800	4720	6840
		60	640	1170	2600	4710	8140	13700
		75	770	1410	3150	5710	9790	14500
		100	990	1800	4070	7310	12500	16000
		150	1420	2580	5850	10500	17000	18000
		200	1850	3370	7630	13700	18000	18500
		300	2700	4910	11200	19800	20000	—
		500	4400	8090	15700	20000	—	—
		750	5400	12000	18000	—	—	—
		1000	5800	14000	—	—	—	—
		1250	6300	—	—	—	—	—
	1500	6600	—	—	—	—	—	
	1750	6800	—	—	—	—	—	
	2000	7600	—	—	—	—	—	
	20	30	350	620	1450	2580	4360	6290
		50	550	1000	2280	4090	7670	14100
		60	640	1170	2640	4750	9690	14500
		100	990	1800	4070	7310	13900	23300
		150	1420	2580	5850	10500	17700	34200
		200	1850	3370	7630	13700	26600	39100
		300	2700	4910	11200	20100	37000	—
		500	4400	8090	18300	32900	—	—
		750	6600	12000	23600	—	—	—
		1000	8900	16000	—	—	—	—
1250		10000	—	—	—	—	—	
1500		10400	—	—	—	—	—	
1750		12000	—	—	—	—	—	
2000	14000	—	—	—	—	—		

- Capacity is based on 20% droop unless otherwise noted. See "Capacity Data" for equivalent capacities of other gases.
- For pressure settings under 10 psig, inlet pressure should be limited to approximately 100 psig so the set point adjustment can be reached.
- For pressure set point of 5 psig, the droop is 2 psig.

DIMENSIONAL DATA

TABLE 2: FLOW CAPACITIES IN SCFH OF 0.6 SPECIFIC GRAVITY NATURAL GAS ⁽¹⁾ (CONT'D)

Outlet Pressure Range	Outlet Pressure Setting (psig)	Inlet Pressure (psig)	Orifice Diameter (inches)					
			3/32	1/8	3/16	1/4	3/8	1/2
15 to 40 psig	40	60	610	1090	2530	4510	9290	9420
		75	760	1370	3080	5640	10800	16500
		100	990	1790	4070	7310	14700	21900
		150	1420	2580	5850	10500	20500	34500
		200	1850	3370	7630	13700	27100	46400
		300	2700	4910	11200	20100	40100	67100
		500	4400	8090	18300	32900	63900	—
		750	6600	12000	27200	39400	—	—
		1000	8700	16000	36100	—	—	—
		1250	11000	19000	—	—	—	—
		1500	13000	22000	—	—	—	—
		1750	15000	—	—	—	—	—
2000	17000	—	—	—	—	—		
35 to 80 psig	60	75	700	1230	2760	4880	8630	16100
		100	970	1740	4010	7000	13000	19300
		150	1420	2580	5850	10500	18900	32800
		200	1850	3370	7630	13700	24000	42200
		300	2700	4910	11200	20100	32500	69100
		500	4400	8090	18300	32900	64000	94300
		750	6600	12000	27200	43380	66900	130000
		1000	8700	16000	36100	50300	67700	—
		1250	11000	19000	45000	57000	—	—
		1500	13000	22000	54000	63000	—	—
	1750	15000	25000	63000	—	—	—	
	2000	17000	28000	—	—	—	—	
	80	100	900	1600	3750	6650	12200	18600
		150	1410	2580	5850	10500	21100	33600
		200	1850	3370	7630	13700	28400	44100
		300	2700	4910	11200	20100	43300	75400
		500	4400	8090	18300	32900	71600	110000
		750	6600	12000	27200	48900	105500	135000
		1000	8700	16000	36100	64900	118000	—
		1250	11000	19000	45000	80000	—	—
1500		13000	22000	54000	96000	—	—	
1750		15000	25000	63000	—	—	—	
2000	17000	28000	—	—	—	—		

1. Capacity is based on 20% droop unless otherwise noted. See "Capacity Data" for equivalent capacities of other gases.

DIMENSIONAL DATA

TABLE 2: FLOW CAPACITIES IN SCFH OF 0.6 SPECIFIC GRAVITY NATURAL GAS ⁽¹⁾ (CONT'D)

Outlet Pressure Range	Outlet Pressure Setting (psig)	Inlet Pressure (psig)	Orifice Diameter (inches)					
			3/32	1/8	3/16	1/4	3/8	1/2
70 to 150 psig	100	150	1170	2510	5540	8710	16000	24000
		200	1850	3370	7630	12000	21300	34100
		300	2700	4910	11200	19400	30100	53200
		500	4400	8090	18300	31800	66500	83900
		750	6600	12000	27200	47300	95300	117000
		1000	8700	16000	36100	59700	10000	120000
		1250	11000	19000	45000	72000	114000	—
		1500	13000	22000	54000	86000	—	—
		1750	15000	25000	63000	95000	—	—
		2000	17000	28000	71000	—	—	—
	125	150	1250	2340	5340	9470	15700	20800
		200	1830	3320	7550	13400	28100	32800
		300	2700	4910	11200	20100	36300	52600
		500	4400	8090	18300	32900	70800	109000
		750	6600	12000	27200	48900	104000	158000
		1000	8700	16000	36100	64800	136000	160000
		1250	11000	19000	45000	80000	145000	—
		1500	13000	22000	54000	96000	—	—
		1750	15000	25000	63000	112000	—	—
		2000	17000	28000	71000	—	—	—
	150	200	1760	3200	7290	12900	21400	33600
		300	2700	4910	11200	17200	40100	55900
		500	4400	8090	18300	32900	70300	111000
		750	6600	12000	27200	48900	104000	160000
		1000	8700	16000	36100	64800	138000	162000
		1250	11000	19000	45000	80000	150000	—
		1500	13000	22000	54000	96000	—	—
1750		15000	25000	63000	112000	—	—	
2000		17000	28000	71000	—	—	—	

1. Capacity is based on 20% droop unless otherwise noted. See "Capacity Data" for equivalent capacities of other gases.

DIMENSIONAL DATA

OVERPRESSURE PROTECTION

As is true with many regulators, the Mark 627 has an outlet pressure rating that is lower than the inlet pressure rating. Overpressure protection is needed to avoid overpressure if the actual inlet pressure can exceed the outlet pressure rating.

CAPACITY DATA

Natural gas regulating capacities for selected inlet pressures and outlet pressure settings are shown in Table 2. Flows are in scfh (60°F and 14.7 psig) of 0.6 specific gravity, natural gas at 60°F. To determine the equivalent capacities for other gases, multiply the table capacity by the following factors: for air use 0.775, for nitrogen use 0.789, for propane use 0.628, or for butane use 0.548. For gases of other specific gravities, multiply the given capacity by 0.775, and divide by the square root of the particular specific gravity.

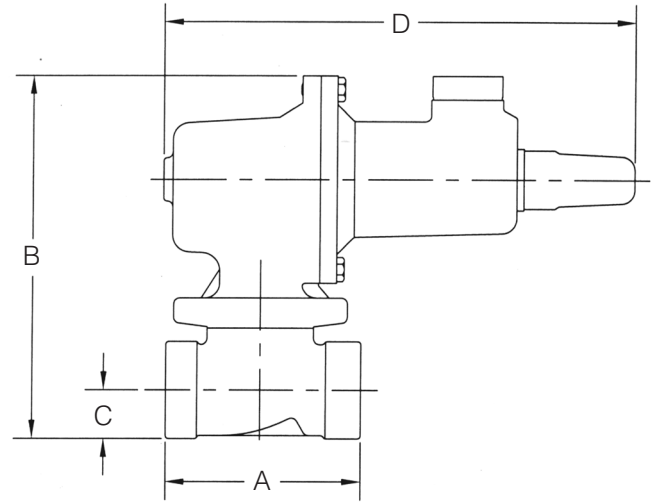

- Inches

Size	A	B	C	D
1"	4.00	7.50	1.00	9.69
2"	5.00	8.56	1.69	10.06

- Metric

Size	A	B	C	D
DN25	102	190,5	25,4	246
DN50	127	217,4	42,9	256

TABLE 3: MAXIMUM SPRING AND DIAPHRAGM HOUSING PRESSURE

Maximum pressure to avoid leakage to atmosphere or possible damage to internal parts.	250 psi
Maximum pressure to prevent burst of housing or possible damage to internal parts.	375 psi
Maximum diaphragm housing overpressure (above set-point) to avoid damage to internal parts.	60 psi

ORDERING SCHEMATIC

To specify a MK627 High Pressure Regulator, build a model number by making a selection from each category in the Product Designator Coding System below.

Model #	Size	/	1	2	3	4	5	6	7

Model	
627	Mark 627 Series

4	Options	
S	Standard Unit	
O	Other (Specify)	

Size	
075	3/4"
100	1"
200	2"

5 & 6	Seat Ring Orifice	
09	3/32"	
12	1/8"	
18	3/16"	
25	1/4"	
38	3/8"	
50	1/2"	

1 & 2	Body Material	
CS	Carbon Steel	

3	Outlet Pressure Range	
1	5 to 20 psig	
2	15 to 40 psig	
3	35 to 80 psig	
4	70 to 150 psig	
9	10 to 95 psig	

7	Trim Material	
6	316SS / Neoprene*	
N	316SS / Nylon	

* JORDAN STANDARD REGULATOR OPTION MEETS NACE REQUIREMENTS.

