

# Delta Element Steam Traps

Models: M40, M100, M64

CRN: Canadian Registration Number Available

## FOR HIGH PRESSURE PROCESS SERVICES

A series of heavy duty steam traps in 1-1/2" and 2" sizes designed specifically for high pressure, high flow process applications, featuring built-in "Y" type strainers and check valves.

- **Maximum differential pressure:** 450 psi (31,0 bar) to 900 psi (62,1 bar)
- **Easy maintenance** – traps are in-line repairable when isolated from live steam system and can be up and running again in minutes
- **Single blade element** – offers long-term, trouble free service because it's not prone to dirt build-up as encountered with many other bimetal designs
- **Stainless Steel internals** – leads to longer service life since materials are highly resistant to fatigue and corrosion
- **Modulating discharge** – automatically adjusts to operating pressure and load
- **Continuous air and CO2 venting** – maximizes heat transfer while minimizing corrosion

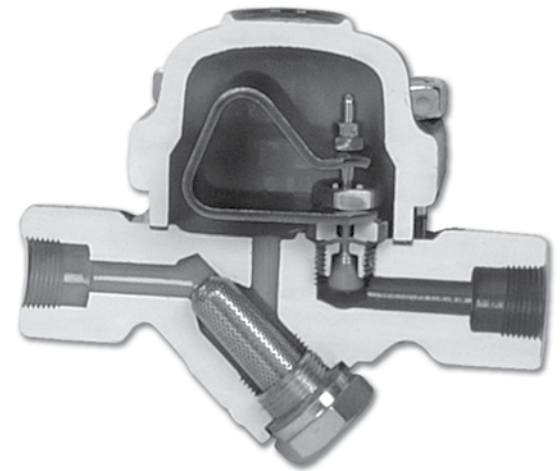

## ORDERING SCHEMATIC

MODEL					6	7	8
M	0	0	4	0			

MODEL					6	7	8
M	0	0	6	4			

MODEL					6	7	8
M	0	1	0	0			

6	SIZE
6	1-1/2"
7	2"

7	CONNECTIONS
1	NPT (All)
2	FSW (All)
5	600# Flange (All)
6	900# Flange (M64, M100)
7	1500# Flange (M100)
8	BSPT (All)
9	BSPP (All)

8	SPECIALITIES
0	None
1	DTC
3	Integral Blowdown



A Division of  
Richards Industries  
3170 Wasson Road  
Cincinnati, OH 45209

toll free. 800.543.7311  
local. 513.533.5600  
fax. 513.871.0105

steam@richardsind.com  
www.bestobellsteamtraps.com

### FOR HIGH PRESSURE PROCESS SERVICES

#### SPECIFICATIONS

##### Maximum Differential Pressure:

Model M40: 450 psi (31,0 bar)

Model M64: 600 psi (41,4 bar)

Model M100: 900 psi (62,1 bar)

Maximum Allowable Pressure: 1500 psig (103,4 bar)

Maximum Allowable Temperature: 750°F (399°C)

#### MATERIALS

Body & Cover: Forged Carbon Steel A105

Valve Seat 17-4 SST (coated) & Stem: 17-4 SST (coated)

Bi-Metal: Stainless Steel NiCr

Strainer: Stainless Steel 304

Bolts: ASTM-A193, B7

Gasket: Flexible Graphite

Options: Double Threaded Strainer Cap (DTC) for blowdown valve attachment; selection of integral blowdown valves

Mounting: From horizontal to vertical (see Installation & Maintenance Instructions). Self-Draining and freeze-resistant when mounted in vertical position.

Line Sizes: All models: 1-1/2", 2"

#### End Connections:

All Models: NPT, BSPT, BSPP, SW, Raised Face Flanged ANSI 600#

M64, M100: Raised Face Flanged ANSI 900#

M100: Raised Face Flanges ANSI 1500#

#### DIMENSIONS

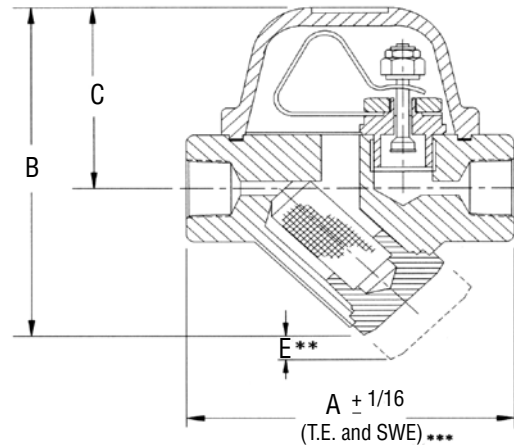

Model M40, M64, M100						
1-1/2", 2"	A	B	C	D	E	Wt
inches	8.00	9.75	6.00	8.00	4.375	50 lbs
mm	203	248	152	203	111	23 kgs

Notes: dimension D is overall width; \*\* dimension E is withdrawal distance for strainer; \*\*\* dimensions shown are for threaded or socket weld ends, contact factory for other dimensions

#### CAPACITY CHARTS: CONDENSATE CAPACITY AT OPERATING PRESSURE

Model M40		Consider M25 in this range				
Size	Operating Pressure, psi (bar)	250 (17,2)	300 (20,7)	350 (24,1)	400 (27,6)	450 (31,0)
1-1/2" & 2"	Cold start-up, lbs/hr	1100	15500	18000	20000	21000
	Hot (Dripleg), lbs/hr	1500	1800	1900	1950	1950
	Cold start-up, Kg/hr	4989	7030	8164	9071	9525
	Hot (Dripleg), Kg/hr	680	816	861	884	884
Model M64		Consider M40 in this range				
Size	Operating Pressure, psi (bar)	400 (27,6)	450 (31,0)	500 (34,5)	550 (37,9)	600 (41,4)
1-1/2" & 2"	Cold start-up, lbs/hr	11000	13250	15500	16500	17500
	Hot (Dripleg), lbs/hr	1900	1950	2000	2050	2100
	Cold start-up, Kg/hr	4989	6010	7030	7484	7937
	Hot (Dripleg), Kg/hr	861	884	907	929	952
Model M100		Consider M64 in this range				
Size	Operating Pressure, psi (bar)	550 (37,9)	600 (41,4)	700 (48,3)	800 (55,2)	900 (62,0)
1-1/2" & 2"	Cold start-up, lbs/hr	16500	17500	19000	20000	21000
	Hot (Dripleg), lbs/hr	2050	2100	2200	2300	2400
	Cold start-up, Kg/hr	7484	7937	8618	9071	9525
	Hot (Dripleg), Kg/hr	929	952	997	1043	1088

Note: Flow rates are based on discharge to atmospheric pressure, valid for back pressure up to 20% of inlet pressure. Higher back pressure requires reset of control element to obtain these capacities. Consult factory for details.

1 year parts & labor warranty available - consult factory for details