

The HH Series is a heavy duty, high pressure needle valve that features an industrial strength stem and bonnet and enhanced packing arrangement all designed to handle the tough conditions of high pressure service.

With a multitude of configurations available, you will find a model to meet your varying needs. The HH Series is produced in 1/8", 1/4", 3/8", 1/2" NPT ends and 1/4", 3/8", and 9/16" cone and thread ends. Other high pressure connections are available upon request. For corrosive or other volatile applications, the HH Series can be specified in a variety of materials including Titanium, Hastelloy and Inconel.

### Features and Benefits

- **Packing Materials:** TFE or high pressure graphite
- **Specifications:**
  - Maximum Working Pressure: up to 15,000 psig (1035 bar)
  - Temperature Ratings: -100°F to 450°F (-73°C to 232°C) with Grafoil packing: -100°F to 850°F (-73°C to 454°C)  
High temperature materials available for service up to 1100°F (593°C)
- **Backseated Bonnets with Packing Below the Stem Threads:** To eliminate potential thread contamination by the process media, the packing is located below the stem threads. Backseating minimizes fugitive emissions with a metal-to-metal backseat that also prevents accidental removal or stem blow-out in operation.
- **Non-Rotating Tip (NRT) Stem:** Provides tight, repeatable shutoff without galling or cross-scoring that occurs on ball type stems. Because the NRT conical stem tip stops rotating when it contacts the seat, further torque turns the stem, but not the tip, protecting the stem tip from damage.

Repeated closures improve the mating between the seat and the stem tip, unlike wear that will occur over time with a ball stem tip.



### Flow Schematic

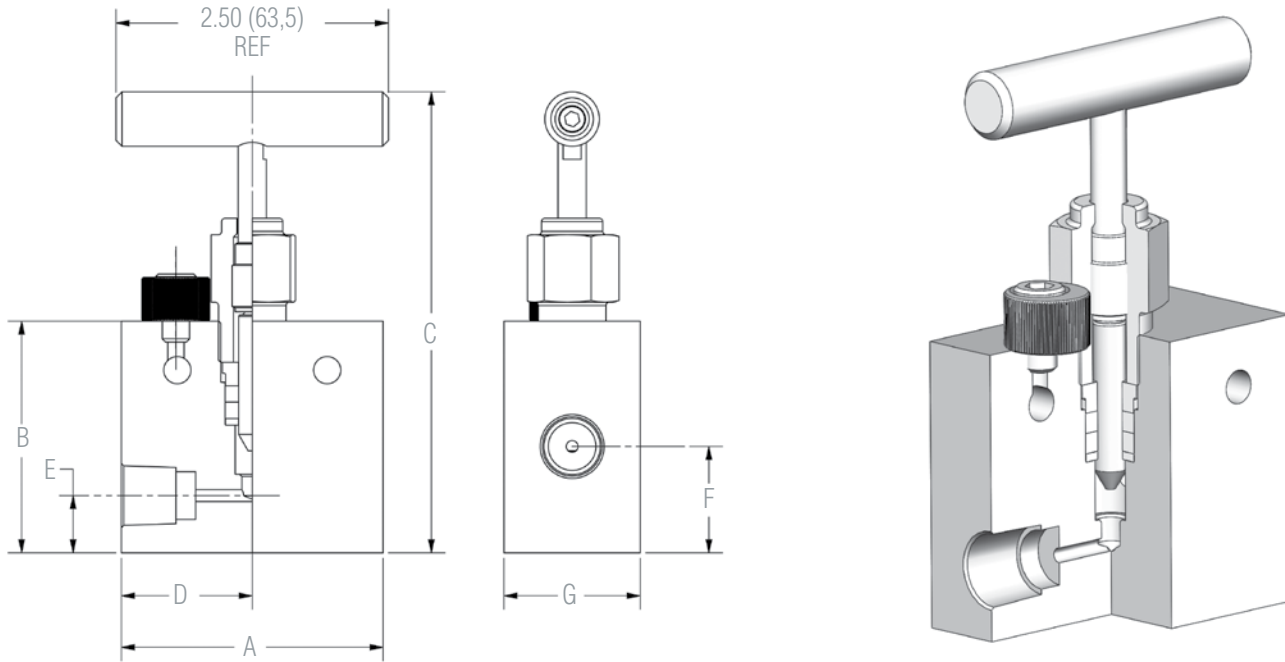

**Dimensions**

Dimensions, Inches (mm)										
Fitting Size	PSI (bar)	Connection	Orifice	A	B	C	D	E	F	G
1/4"	15,000 (1035)	C & T	0.158 (4,0)	2.68 (68)	2.85 (72,4)	5.21 (132,3)	1.34 (34)	0.60 (15,2)	1.10 (27,9)	1.25 (31,8)
3/8"	15,000 (1035)	C & T	0.197 (5,0)	2.68 (68)	2.85 (72,4)	5.21 (132,3)	1.34 (34)	0.60 (15,2)	1.10 (27,9)	1.25 (31,8)
9/16"	15,000 (1035)	C & T	0.312 (8,0)	2.68 (68)	3.25 (82,6)	5.61 (142,5)	1.34 (34)	1.00 (25,4)	1.50 (38,1)	1.75 (44,5)

Dimensions, Inches (mm)										
Fitting Size	PSI (Mpa)	Connection	Orifice	A	B	C	D	E	F	G
1/8"	15,000 (1035)	NPT	0.197 (5,0)	2.68 (68)	2.85 (72,4)	5.21 (132,3)	1.34 (34)	0.60 (15,2)	1.10 (27,9)	1.25 (31,8)
1/4"	15,000 (1035)	NPT	0.237 (6,0)	2.68 (68)	2.85 (72,4)	5.21 (132,3)	1.34 (34)	0.60 (15,2)	1.10 (27,9)	1.25 (31,8)
3/8"	15,000 (1035)	NPT	0.312 (8,0)	2.68 (68)	3.25 (82,6)	5.61 (142,5)	1.34 (34)	1.00 (25,4)	1.50 (38,1)	1.75 (44,5)
1/2"	15,000 (1035)	NPT	0.312 (8,0)	2.68 (68)	3.65 (92,7)	6.01 (152,7)	1.34 (34)	1.37 (34,8)	1.87 (47,5)	2.25 (57,2)

Model	5	6	7	8	9	10	11	12

Model Number	
HH15	Standard
HH15S	Super Critical Steam

5	Configuration
1	Straight
2	Angled

6	Material
D	316SS NACE
E*	Titanium (Gr.2)
H**	Hastelloy-C
I**	Incoloy-800
J**	Inconel-600
U	316SS
W	316L SS NACE
5**	Incoloy 825
7**	Inconel 625
8**	316H SS

\* Max Temperature 1000°F (538°C)

\*\* Max Temperature 1100°F (593°C)

6	Inlet Size
1	Integral

7	Inlet Size
1	1/4"
2	3/8"
3	9/16" (C & T only)
4	1/8" (NPT only)
5	1/2" (NPT & MSW only)

8	Inlet Type
1	Med Press C&T
2	High Press C&T
3	NPT
4	MSW

9	Outlet Size
1	1/4"
2	3/8"
3	9/16" (C & T only)
4	1/8" (NPT only)
5	1/2" (NPT & MSW only)

10	Outlet Type
1	Med Press C&T
2	High Press C&T
3	NPT
4	MSW

11	Stem/tip
0	316/316L/316L NACE
3	316/316 NACE
4	316/316SS
5	316/Stellite
6	I-600/I-600
8	316H/316H
D	HAS-C/HC
J	316/17-4
Q	I-825/I-825
R	17-4PH/17-4 PH
Y	316L/316L

12	Packing
2	TFE
3	Graphite